

BACnet/IP Servers to ASCII

FEATURES

- Fully configurable BACnet/IP client
- BACnet/IP supports device, binary I/O/V, analog I/O/V, multi-state I/O/V, and character string value object types
- Parse ASCII data in up to 50 segments by delimiter or offset
- Concatenate up to 50 data segments into a string
- Effortless Browser Based Configuration, no programming software is required
- Simple data translation allows you to manipulate data as it passes between protocols
- Guaranteed Stock
- 5-Year Hardware Warranty

Deliver Data from Your BACnet/IP Server Devices to an ASCII-Based System or Controller

The 460BCA moves data between up to 32 BACnet/IP server devices and serial ASCII.

It's a great tool to implement BACnet/IP devices into your PC or embedded applications that support raw ASCII data.

How Do I Use the 460BCA-N2EW in My Application?

BACnet analog, binary, and CSV data segments can be converted to ASCII and delivered to your ASCII controller. If you need to command the BACnet/IP servers, an incoming ASCII string can be parsed and directed to user-defined data location.

Need to scale your data or manipulate it with other math functions? The 460BCA allows you to add scaling to any data, apply simple math operations, add alarming, and control the request speeds of your server devices.

Why Use Real Time Automation as a Gateway Supplier?

While there are certainly other companies offering protocol gateways, there is no one who provides the level of support and service that you receive from RTA.

When you call, a live person answers the phone. When you talk with sales, you will get honest answers and recommendations. When you get support, it is from an engineer who had a hand in the product's development, and support doesn't require a ticket or 24-hour wait.



A Solution, A Philosophy, the RTA Way. We understand the long hours spent on a factory floor and the pressure to keep a line running and product flowing. That's how Real Time Automation came to be. You want easy-to-use solutions where the hardest part is to open the box. You need customer support second to none. If you get all that and a fun customer experience all the better. Thirty years later, our mission remains the same: **To move your data where you need it, when you need it, and how you need it.**

BACnet/IP Client	
Operation Mode	BACnet/IP Client
Supported Object Types	Device, BI/BO/BV, AI/AO/AV, MI/MO/MV, Character String Value
Supported Service Codes	Read Property-A, Read Property Multiple-A, Write Property-A, Write Property Multiple-A, Device Dynamic Binding-A
Maximum Connections	32
Number Read/Write Scan Lines per Device	200 Total - 100 reads & 100 writes
Scan Line Support	Up to 128 Objects
ASCII	
Operation Mode	Bidirectional ASCII Transmit and Receive
Maximum Number of Devices Supported	2
Concatenation	Concatenate up to 50 segments data in a delimited ASCII sting
Maximum Number of ASCII Characters Transferred	1024 in each direction
Delimiter Processing	Incoming delimiters can be automatically removed; Outgoing delimiters automatically added if configured
Parsing	Parse string of ASCII data in up to 50 segments by delimiter or offset
INCLUDED WITH GATEWAY	
3' power cable with flying leads	5-year hardware warranty
IPSetup software – automatically locates RTA gateway on the network	Unlimited firmware feature upgrades for life
CAT5 crossover cable for direct connection to PC during programming	Complete, unlimited access to our industry leading support staff
Manual	

ELECTRICAL / ENVIRONMENTAL	
DC Input Voltage	12-24 VDC
Maximum Baud Rate	115K baud
Operating Temperature	-40 C to 85 C
Certification	RoHS-Compliant, UL, CUL, CE Approvals, Class I Div 2
ENCLOSURE / HARDWARE	
Size	5.40" x 3.83" x 1.19"
Weight	7.6 oz
Enclosure Type	Anodized Aluminum
Mounting	Din rail or panel mount
LEDs	Power LED & 2 general purpose LEDs on side
GATEWAY FEATURES & FUNCTIONS	
Alarming	Set <, <=, >, >=, ==, !=, and change-of-state rules on any data moving through the gateway. If alarm rule is triggered an email notification can be sent.
Gateway Security	You can configure up to 9 different users access to diagnostic and configuration screens.
Translation Table	Allows for data manipulation during protocol translation. Scaling and other data format changes can occur in the gateway.
Status and Counters	Protocol specific status, counters, and error messages are accessible within the gateway's diagnostics page. They can also be delivered to a connected device.
Diagnostic Logging Page	Allows users to see and log start up sequences, protocol specific messages & error messages.

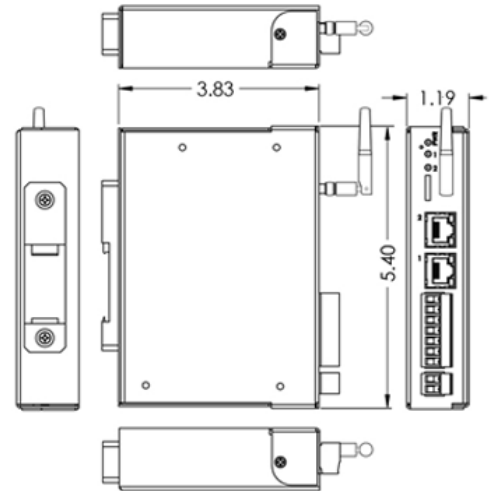

NOT EXACTLY WHAT YOU WERE LOOKING FOR?
 Real Time Automation offers a full line of gateway products. Give us a call at 1-800-249-1612. Or, check out a listing at www.rtautomation.com/products. We also offer customizations for unique applications.

CATALOG #	DESCRIPTION
460BCA-N2EW	Connects up to 32 BACnet/IP servers with an ASCII device



Made in the
U.S.A. 

Always In
Stock 

Ready to
Ship 

Expert
Support 