

## Wireless Web Interface to BACnet/IP Servers

### FEATURES

- Fully configurable BACnet/IP client
- BACnet/IP supports device, binary I/O/V, analog I/O/V, multi-state I/O/V, and character string value object types
- Get PLC data table entries encoded in either JSON or XML
- Bidirectional data transfer supports both HTTP GET and POST
- Effortless Browser Based Configuration, no programming software is required
- Simple data translation allows you to manipulate data as it passes between protocols
- 5-Year Hardware Warranty

### Deliver Data from Your BACnet/IP Server Devices from a Web Client over Wi-Fi

The 460BCWI moves data wirelessly between up to 32 BACnet/IP server devices and your web application using Wi-Fi IEEE 802.11 b/g/n at 2.4GHz with AES encryption 128-bit. Use that data to easily build a dashboard, archive data, or create a sophisticated alarm system. The gateway presents the data as JSON or XML files transferred via HTTP commands. Best of all, the product is made in the USA, always in stock, and comes with a 5-year warranty.

### How Do I Use the 460BCWI-N2EW in My Application?

First, you configure the 460BCWI using the browser-based configuration pages. You'll identify the data set to read / write on BACnet. Once that's complete, you'll map, name, and group the data to be presented as XML or JSON files. Your application can issue standard HTTP GET or POST instructions to move data into your application. Up to 1000 data points can be moved in each direction.

### Why Use Real Time Automation as a Gateway Supplier?

While there are certainly other companies offering protocol gateways, there is no one who provides the level of support and service that you receive from RTA.

When you call, a live person answers the phone. When you talk with sales, you will get honest answers and recommendations. When you get support, it is from an engineer who had a hand in the product's development, and support doesn't require a ticket or 24-hour wait.

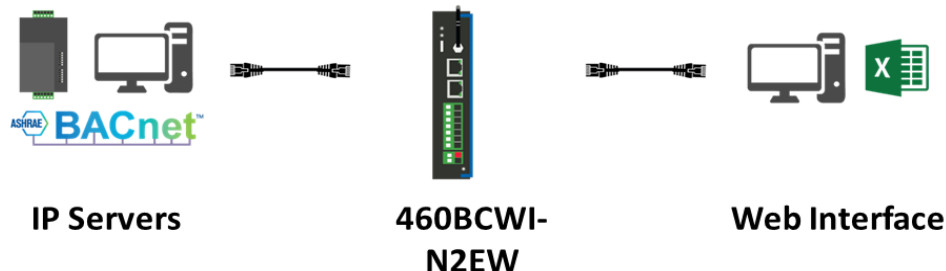

**A Solution, A Philosophy, the RTA Way.** We understand the long hours spent on a factory floor and the pressure to keep a line running and product flowing. That's how Real Time Automation came to be. You want easy-to-use solutions where the hardest part is to open the box. You need customer support second to none. If you get all that and a fun customer experience all the better. Thirty years later, our mission remains the same: **To move your data where you need it, when you need it, and how you need it.**

BACnet/IP Client FEATURES	
Operation Mode	BACnet/IP Client
Supported Object Types	Device, BI/BO/BV, AI/AO/AV, MI/MO/MV, Character String Value
Supported Service Codes	Read Property-A, Read Property Multiple-A, Write Property-A, Write Property Multiple-A, Device Dynamic Binding-A
Maximum Connections	32
Number Read/Write Scan Lines per Device	200 Total - 100 reads & 100 writes
Scan Line Support	Up to 128 Objects
Web Interface FEATURES	
Max Web Interface Connections	One (gateway acting as client) / Unlimited (gateway acting as server)
Encodings	JSON and XML
Proxy Support	HTTP, SOCKS5 for Client
Maximum Number of Input Data Points	1000 JSON Fields or 1000 XML Tags
Maximum Number of Output Data Points	1000 JSON Fields or 1000 XML Tags
HTTP Services	Client: POST only; Server: GET and POST
INCLUDED WITH GATEWAY	
3' power cable with flying leads	5-year hardware warranty
IPSetup software – automatically locates RTA gateway on the network	Unlimited firmware feature upgrades for life
CAT5 crossover cable for direct connection to PC during programming	Complete, unlimited access to our industry leading support staff
Manual	

ELECTRICAL / ENVIRONMENTAL	
DC Input Voltage	12-24 VDC
Maximum Baud Rate	115K baud
Operating Temperature	-40 C to 85 C
Certification	RoHS-Compliant, UL, CUL, CE Approvals, Class I Div 2
ENCLOSURE / HARDWARE	
Size	5.40" x 3.83" x 1.19"
Weight	7.6 oz
Enclosure Type	Anodized Aluminum
Mounting	Din rail or panel mount
LEDs	Power LED & 2 general purpose LEDs on side
GATEWAY FEATURES & FUNCTIONS	
Alarming	Set <, <=, >, >=, ==, !=, and change-of-state rules on any data moving through the gateway. If alarm rule is triggered an email notification can be sent.
Gateway Security	You can configure up to 9 different users access to diagnostic and configuration screens.
Translation Table	Allows for data manipulation during protocol translation. Scaling and other data format changes can occur in the gateway.
Status and Counters	Protocol specific status, counters, and error messages are accessible within the gateway's diagnostics page. They can also be delivered to a connected device.
Diagnostic Logging Page	Allows users to see and log start up sequences, protocol specific messages & error messages.

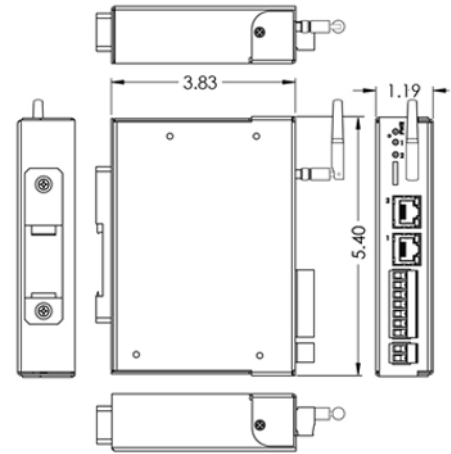

**NOT EXACTLY WHAT YOU WERE LOOKING FOR?**  
 Real Time Automation offers a full line of gateway products. Give us a call at 1-800-249-1612. Or, check out a listing at [www.rtautomation.com/products](http://www.rtautomation.com/products). We also offer customizations for unique applications.

CATALOG #	DESCRIPTION
460BCWI-N2EW	Connects up to 32 BACnet/IP servers from a web client over wireless



MADE IN THE  
**U.S.A.**



ALWAYS IN  
**STOCK**



READY TO  
**SHIP**



EXPERT  
**SUPPORT**

