

Ethernet TCP/IP to BACnet MS/TP Slaves

FEATURES

- Fully configurable BACnet MS/TP master
- BACnet MS/TP supports device, binary I/O/V, analog I/O/V, multi-state I/O/V, and character string value object types
- Support up to 10 TCP/IP devices
- Parse & concatenate ASCII data in up to 50 segments by delimiter or offset
- Effortless Browser Based Configuration, no programming software is required
- Simple data translation allows you to manipulate data as it passes between protocols
- 5-Year Hardware Warranty

Get Ethernet TCP/IP Data into your BACnet MS/TP Slave Devices

The 460BMTCP moves data between up to 10 Ethernet TCP/IP devices and up to 32 BACnet MS/TP slave devices. It's a perfect tool to tie Ethernet TCP/IP devices into your BACnet MS/TP building automation system.

A great tool to connect printers, RFID devices, LED displays and PC applications to a BACnet MS/TP system.

How Do I Use the 460BMTCP-N2E in My Application?

BACnet analog, binary, and CSV data segments can be converted to ASCII and delivered to your ASCII controller. If you need to command the BACnet/IP servers, an incoming ASCII string can be parsed and directed to user-defined data location. It's really that simple. Need to modify your data as it passes from one protocol to the other? No problem. Each data mapping you apply can be modified with up to three mathematic functions. Need to add or remove delimiters between segments, it does that too.

Why Use Real Time Automation as a Gateway Supplier?

While there are certainly other companies offering protocol gateways, there is no one who provides the level of support and service that you receive from RTA.

When you call, a live person answers the phone. When you talk with sales, you will get honest answers and recommendations. When you get support, it is from an engineer who had a hand in the product's development, and support doesn't require a ticket or 24-hour wait.

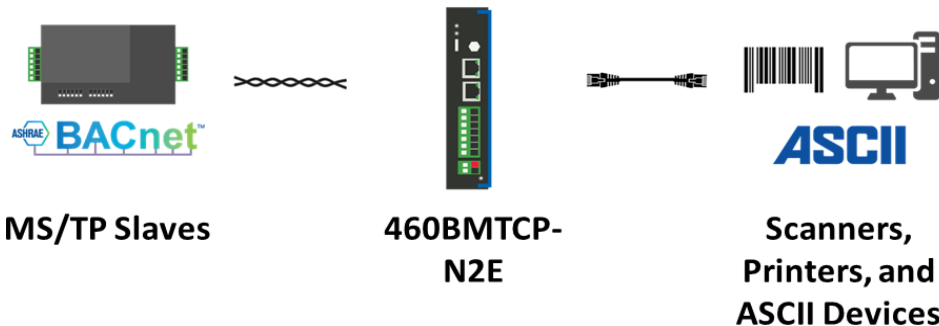

A Solution, A Philosophy, the RTA Way. We understand the long hours spent on a factory floor and the pressure to keep a line running and product flowing. That's how Real Time Automation came to be. You want easy-to-use solutions where the hardest part is to open the box. You need customer support second to none. If you get all that and a fun customer experience all the better. Thirty years later, our mission remains the same: **To move your data where you need it, when you need it, and how you need it.**

BACnet MS/TP Master FEATURES	
Operation Mode	BACnet MS/TP Master Initiator
Supported Object Types	Device, BI/BO/BV, AI/AO/AV, MI/MO/MV, Character String Value
Supported Service Codes	Read Property-A, Read Property Multiple-A, Write Property-A, Write Property Multiple-A, Device Dynamic Binding-A
Maximum Connections	32
Number Read/Write Scan Lines per Device	200 Total - 100 reads & 100 writes
Scan Line Support	Up to 128 Objects
Ethernet TCP/IP FEATURES	
Operation Mode	Client or Server
Maximum Number of Devices Supported	10
Maximum Number of Characters Transferred	1024
Delimiter Processing	Incoming delimiters can be automatically removed; Outgoing delimiters automatically added if configured
Parsing	Parse String of ASCII Data in up to 50 Segments by Delimiter or Offset
Concatenation	Concatenate up to 50 segments/strings of ASCII data with optional delimiter
INCLUDED WITH GATEWAY	
3' power cable with flying leads	5-year hardware warranty
IPSetup software – automatically locates RTA gateway on the network	Unlimited firmware feature upgrades for life
CAT5 crossover cable for direct connection to PC during programming	Complete, unlimited access to our industry leading support staff
Manual	

ELECTRICAL / ENVIRONMENTAL	
DC Input Voltage	12-24 VDC
Maximum Baud Rate	115K baud
Operating Temperature	-40 C to 85 C
Certification	RoHS-Compliant, UL, CUL, CE Approvals, Class I Div 2
ENCLOSURE / HARDWARE	
Size	5.40" x 3.83" x 1.19"
Weight	7.6 oz
Enclosure Type	Anodized Aluminum
Mounting	Din rail or panel mount
LEDs	Power LED & 2 general purpose LEDs on side
GATEWAY FEATURES & FUNCTIONS	
Alarming	Set <, <=, >, >=, ==, !=, and change-of-state rules on any data moving through the gateway. If alarm rule is triggered an email notification can be sent.
Gateway Security	You can configure up to 9 different users access to diagnostic and configuration screens.
Translation Table	Allows for data manipulation during protocol translation. Scaling and other data format changes can occur in the gateway.
Status and Counters	Protocol specific status, counters, and error messages are accessible within the gateway's diagnostics page. They can also be delivered to a connected device.
Diagnostic Logging Page	Allows users to see and log start up sequences, protocol specific messages & error messages.

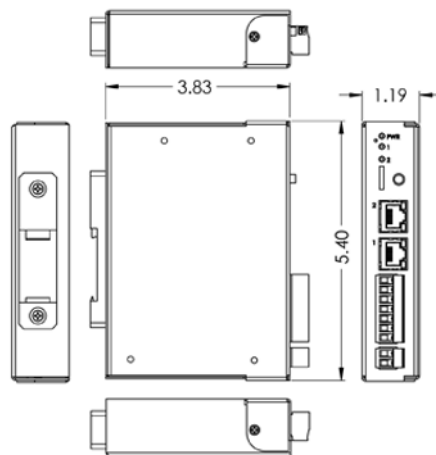

NOT EXACTLY WHAT YOU WERE LOOKING FOR?
 Real Time Automation offers a full line of gateway products. Give us a call at 1-800-249-1612. Or, check out a listing at www.rtautomation.com/products. We also offer customizations for unique applications.

CATALOG #	DESCRIPTION
460BMTCP-N2E	Connects up to 32 BACnet MS/TP slaves with up to 10 Ethernet TCP/IP devices



MADE IN THE
U.S.A.



ALWAYS IN
STOCK



READY TO
SHIP

