

## EtherNet/IP to BACnet/IP Server

### FEATURES

- Fully configurable EtherNet/IP scanner
- Map data from up to 32 EtherNet/IP adapters
- Fully configurable BACnet/IP client
- BACnet/IP supports device, binary I/O/V, analog I/O/V, multi-state I/O/V, and character string value object types
- Effortless Browser Based Configuration, no programming software is required
- Simple data translation allows you to manipulate data as it passes between protocols
- 5-Year Hardware Warranty

### Connect EtherNet/IP Adapter Devices to BACnet/IP Servers

The 460ECBC moves data between a network of up to 32 BACnet/IP server devices and an EtherNet/IP network of up to 32 adapter devices. It's the perfect tool to tie all of your EtherNet/IP devices in with your BACnet/IP devices. Bridge your factory automation systems with your building automation systems.

### How Do I Use the 460ECBC-NNA1 in My Application?

Up to 496 bytes of data from your EtherNet/IP adapters will be mapped to your BACnet/IP servers. When writing from your BACnet/IP servers to your EtherNet/IP adapters, BACnet/IP data will be mapped to up to 32 EtherNet/IP adapters as EtherNet/IP data.

It's really that simple. Need to modify your data as it passes from one protocol to the other? No problem. Each data mapping you apply can be modified with up to three mathematic functions. Add 4 to a value, multiply by 4 and divide by 10 with ease.

### Why Use Real Time Automation as a Gateway Supplier?

While there are certainly other companies offering protocol gateways, there is no one who provides the level of support and service that you receive from RTA.

When you call, a live person answers the phone. When you talk with sales, you will get honest answers and recommendations. When you get support, it is from an engineer who had a hand in the product's development, and support doesn't require a ticket or 24-hour wait.

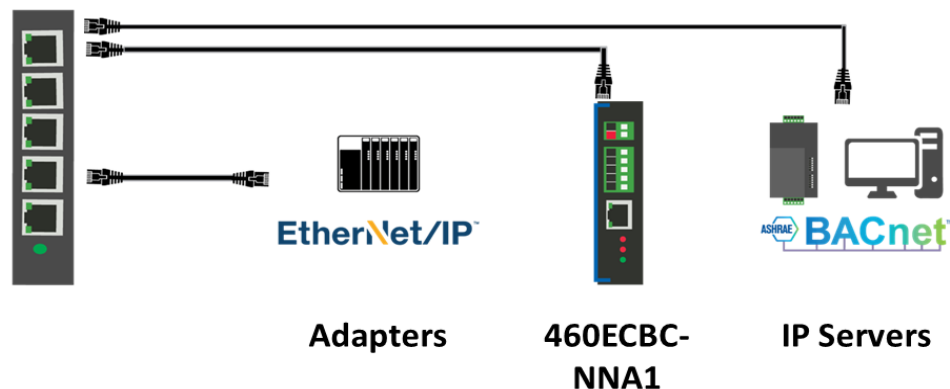

**A Solution, A Philosophy, the RTA Way.** We understand the long hours spent on a factory floor and the pressure to keep a line running and product flowing. That's how Real Time Automation came to be. You want easy-to-use solutions where the hardest part is to open the box. You need customer support second to none. If you get all that and a fun customer experience all the better. Thirty years later, our mission remains the same: **To move your data where you need it, when you need it, and how you need it.**

EtherNet/IP Scanner FEATURES	
Operation Mode	Class 1 I/O Scanner
Message Support	Implicit Class 1 Cyclic I/O, Explicit not supported
Data Types	BIT8,16 & 32; INT8, 16, 32 & 64; UINT8,16, 32 & 64; Float & Double
Maximum EtherNet/IP Adapter Devices	32
Max Data Per Adapter Connection	Up to 496 bytes in each direction
Maximum IO Scan Rate	20 msec
BACnet/IP Client FEATURES	
Operation Mode	BACnet/IP Client
Supported Object Types	Device, BI/BO/BV, AI/AO/AV, MI/MO/MV, Character String Value
Supported Service Codes	Read Property-A, Read Property Multiple-A, Write Property-A, Write Property Multiple-A, Device Dynamic Binding-A
Maximum Connections	32
Number Read/Write Scan Lines per Device	200 Total - 100 reads & 100 writes
Scan Line Support	Up to 128 Objects
INCLUDED WITH GATEWAY	
3' power cable with flying leads	5-year hardware warranty
IPSetup software – automatically locates RTA gateway on the network	Unlimited firmware feature upgrades for life
CAT5 crossover cable for direct connection to PC during programming	Complete, unlimited access to our industry leading support staff
Manual	

ELECTRICAL / ENVIRONMENTAL	
DC Input Voltage	12-24 VDC
Maximum Baud Rate	115K baud
Operating Temperature	-40 C to 85 C
Certification	RoHS-Compliant, UL, CUL, CE Approvals
ENCLOSURE / HARDWARE	
Size	3.88" x 2.57" x 1.06"
Weight	5.5 oz
Enclosure Type	Anodized Aluminum
Mounting	Din rail or panel mount
LEDs	Power LED & 2 general purpose LEDs on side
GATEWAY FEATURES & FUNCTIONS	
Alarming	Set <, <=, >, >=, ==, !=, and change-of-state rules on any data moving through the gateway. If alarm rule is triggered an email notification can be sent.
Gateway Security	You can configure up to 9 different users access to diagnostic and configuration screens.
Translation Table	Allows for data manipulation during protocol translation. Scaling and other data format changes can occur in the gateway.
Status and Counters	Protocol specific status, counters, and error messages are accessible within the gateway's diagnostics page. They can also be delivered to a connected device.
Diagnostic Logging Page	Allows users to see and log start up sequences, protocol specific messages & error messages.

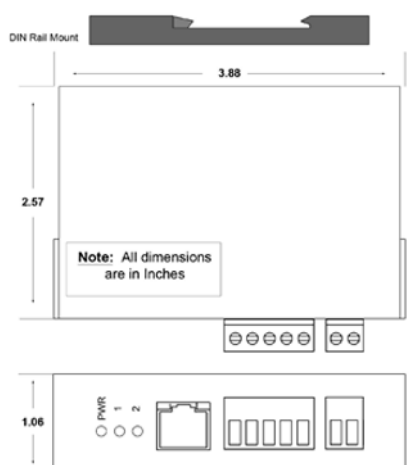

**NOT EXACTLY WHAT YOU WERE LOOKING FOR?**  
 Real Time Automation offers a full line of gateway products. Give us a call at 1-800-249-1612. Or, check out a listing at [www.rtautomation.com/products](http://www.rtautomation.com/products). We also offer customizations for unique applications.

CATALOG #	DESCRIPTION
460ECBC-NNA1	Connects up to 32 EtherNet/IP adapters with as many as 32 BACnet/IP servers



**MADE IN THE U.S.A.**



**ALWAYS IN STOCK**



**READY TO SHIP**



**EXPERT SUPPORT**

