

Wireless Connect Ethernet TCP/IP to EtherNet/IP Gateway

FEATURES

- Fully Configurable EtherNet/IP Adapter
- Supports Up To 480 Bytes of Input and 480 Bytes of Output Data
- Support up to 10 TCP/IP devices
- Parse & Concatenate ASCII data in up to 50 segments by delimiter or offset
- Effortless Browser Based Configuration, no programming software is required
- Simple data translation allows you to manipulate data as it passes between protocols
- Guaranteed Stock
- 5-Year Hardware Warranty

Get Data from an EtherNet/IP Scanner into Your Ethernet TCP/IP Devices

The 460ESTCP allows you to move ASCII data inside TCP/IP packets to an EtherNet/IP PLC. It allows you to interrupt the ASCII data strings into meaningful data types for use in your PLC. Connect to your EtherNet/IP scanner or Ethernet TCP/IP devices over Wi-Fi using Wi-Fi IEEE 802.11 b/g/n at 2.4GHz with AES encryption 128-bit.

Best of all, the product is made in the USA, always in stock, and comes with 5-year warranty.



How do I use the 460ESTCP-N2EW in my application?

Up to 480 bytes of data can be mapped between EtherNet/IP and up to 10 Ethernet TCP/IP devices. Data coming from the TCP/IP device(s) can be parsed and assigned a data type on EtherNet/IP. EtherNet/IP data can be sent as a string of data over TCP/IP.

It's really that simple. Need to modify your data as it passes from one protocol to the other? No problem. Each data mapping you apply can be modified with up to three mathematic functions. Add 4 to a value, multiply by 4 and divide by 10 with ease.

Why Use Real Time Automation as a Gateway Supplier?

While there are certainly other companies offering protocol gateways, there is no one who provides the level of support and service that you receive from RTA.

When you call, a live person answers the phone. When you talk with sales, you will get honest answers and recommendations. When you get support, it is from an engineer who had a hand in the product's development, and support doesn't require a ticket or 24-hour wait.

Try the RTA difference today! Call us at 800-249-1612 or check out our solutions at rtautomation.com

A Solution, A Philosophy, the RTA Way. We understand the long hours spent on a factory floor and the pressure to keep a line running and product flowing. That's how Real Time Automation came to be. You want easy-to-use solutions where the hardest part is to open the box. You need customer support second to none. If you get all that and a fun customer experience, all the better. Thirty years later, our mission remains the same: **to move your data where you need it, when you need it and how you need it.**

EtherNet/IP Adapter FEATURES	
Operation Mode	Class 1 I/O Adapter
Message Support	4
Data Types	BIT8,16 & 32; INT8, 16, 32 & 64; UINT8,16, 32 & 64; Float & Double
Maximum EtherNet/IP Scanner Devices	Up to 10 can listen, only 1 can write I/O
Maximum Data Supported	Up to 480 bytes in each direction
Maximum IO Scan Rate	20 msec
Ethernet TCP/IP FEATURES	
Operation Mode	Client or Server
Maximum Number of Devices Supported	10
Maximum Number of Characters Transferred	1024
Delimiter Processing	Incoming delimiters can be automatically removed; Outgoing delimiters automatically added if configured
Parsing	Parse String of ASCII Data in up to 50 Segments by Delimiter or Offset
Concatenation	Concatenate up to 50 segments/strings of ASCII data with optional delimiter
INCLUDED WITH GATEWAY	
3' power cable with flying leads	5-year hardware warranty
IPSetup software – automatically locates RTA gateway on the network	Unlimited firmware feature upgrades for life
CAT5 crossover cable for direct connection to PC during programming	Complete, unlimited access to our industry leading support staff
Manual	

ELECTRICAL / ENVIRONMENTAL	
DC Input Voltage	12-24 VDC
Maximum Baud Rate	115K baud
Operating Temperature	-40 C to 85 C
Certification	RoHS-Compliant, UL, CUL, CE Approvals, Class I Div 2

ENCLOSURE / HARDWARE	
Size	5.40" x 3.83" x 1.19"
Weight	7.6 oz
Enclosure Type	Anodized Aluminum
Mounting	Din rail or panel mount
LEDs	Power LED & 2 general purpose LEDs on side

GATEWAY FEATURES & FUNCTIONS	
Alarming	Set <, <=, >, >=, ==, !=, and change-of-state rules on any data moving through the gateway. If alarm rule is triggered an email notification can be sent.
Gateway Security	You can configure up to 9 different users access to diagnostic and configuration screens.
Translation Table	Allows for data manipulation during protocol translation. Scaling and other data format changes can occur in the gateway.
Status and Counters	Protocol specific status, counters, and error messages are accessible within the gateway's diagnostics page. They can also be delivered to a connected device.
Diagnostic Logging Page	Allows users to see and log start up sequences, protocol specific messages & error messages.

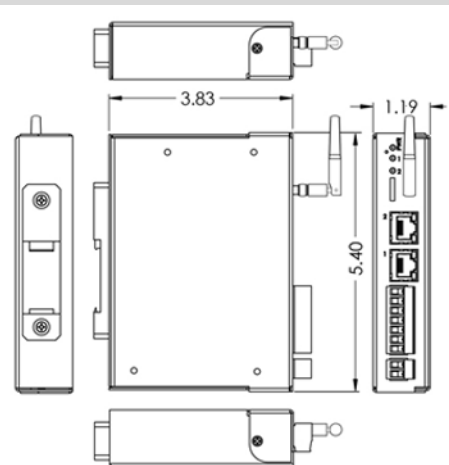

NOT EXACTLY WHAT YOU WERE LOOKING FOR?
 Real Time Automation offers a full line of gateway products. Give us a call at 1-800-249-1612. Or, check out a listing at www.rtautomation.com/products. We also offer customizations for unique applications.

CATALOG #	DESCRIPTION
460ESTCP-N2EW	Connects an EtherNet/IP scanner with as many as 10 Ethernet TCP/IP devices



Made in the
U.S.A.

Always In
Stock

Ready to
Ship

Expert
Support