

Wireless Modbus RTU to Allen-Bradley PLC

FEATURES

- Supports connection to five Allen-Bradley PLCs
- Up to 150 tag or file arrays of data can be mapped in each direction
- Fully configurable Modbus RTU Client
- Connects up to 32 Modbus RTU Servers
- Effortless Browser Based Configuration, no programming software is required
- Simple data translation allows you to manipulate data as it passes between protocols
- 5-Year Hardware Warranty

Get Your Modbus RTU Server Devices Connected Directly to the Data Table of Your Allen-Bradley PLC over Wi-Fi

The 460ETCMM moves data wirelessly between up to 32 Modbus RTU Server devices and up to five Allen-Bradley PLCs using Wi-Fi IEEE 802.11 b/g/n at 2.4GHz with AES encryption 128-bit. It saves legacy Modbus RTU devices from the scrap pile and allows you to use the many of Modbus RTU devices available in your A-B PLC architectures.

Best of all, the product is made in the USA and comes with 5-year warranty.

How Do I Use the 460ETCMM-N2EW in My Application?

You allocate two blocks in your Allen-Bradley PLC. One area is write only tags or register blocks accepting data from your Modbus RTU devices. The other area is read only tags or register blocks to send data to your Modbus RTU devices.

It's really that simple. Need to modify your data as it passes from one protocol to the other? No problem. Each data mapping you apply can be modified with up to three mathematic functions. Add 4 to a value, multiply by 4 and divide by 10 with ease.

Why Use Real Time Automation as a Gateway Supplier?

While there are certainly other companies offering protocol gateways, there is no one who provides the level of support and service that you receive from RTA.

When you call, a live person answers the phone. When you talk with sales, you will get honest answers and recommendations. When you get support, it is from an engineer who had a hand in the product's development, and support doesn't require a ticket or 24-hour wait.

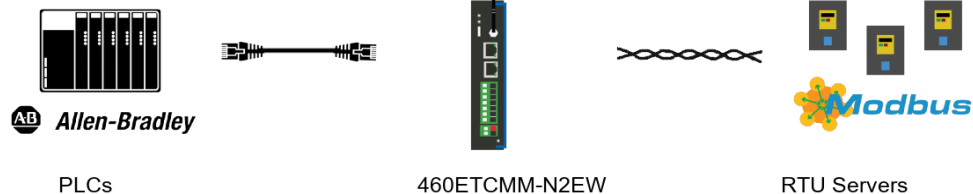

A Solution, A Philosophy, the RTA Way. We understand the long hours spent on a factory floor and the pressure to keep a line running and product flowing. That's how Real Time Automation came to be. You want easy-to-use solutions where the hardest part is to open the box. You need customer support second to none. If you get all that and a fun customer experience all the better. Thirty years later, our mission remains the same: **To move your data where you need it, when you need it, and how you need it.**

ETHERNET TAG CLIENT FEATURES	
PLC Support	ControlLogix, CompactLogix, FlexLogix, MicroLogix, SLCs and PLC5Es
Maximum Number of PLCs Supported	5
Maximum Number of Input/Output Tags or Files per PLC	150
Maximum Number of Bytes per PLC Tag	400
Array Support	Yes, for all data types except strings
Supported Data Types	Usint, Sint, Uint, Int, Uuint, Dint, Real, String, Bit Array 16, Bit Array 32, Bool, and Long
MODBUS RTU CLIENT FEATURES	
Operation Mode	Modbus RTU Client
Function Codes Supported	1,2,3,4,5,6, 15 & 16
Swapping	Byte and Word Swapping
Maximum Modbus RTU Server Devices	32
Number Read/Write Scan Lines per RTU Server Device	200 Total - 100 reads & 100 writes
Scan Line Support	Up to 125 Registers or 512 Coils
INCLUDED WITH GATEWAY	
3' power cable with flying leads	5-year hardware warranty
IPSetup software – automatically locates RTA gateway on the network	Unlimited firmware feature upgrades for life
CAT5 crossover cable for direct connection to PC during programming	Complete, unlimited access to our industry leading support staff
Manual	

ELECTRICAL / ENVIRONMENTAL	
DC Input Voltage	12-24 VDC
Maximum Baud Rate	115K baud
Operating Temperature	-40 C to 85 C
Certification	RoHS-Compliant, UL, CUL, CE Approvals, Class I Div 2
ENCLOSURE / HARDWARE	
Size	5.40" x 3.83" x 1.19"
Weight	7.6 oz
Enclosure Type	Anodized Aluminum
Mounting	Din rail or panel mount
LEDs	Power LED & 2 general purpose LEDs on side
GATEWAY FEATURES & FUNCTIONS	
Alarming	Set <, <=, >, >=, ==, !=, and change-of-state rules on any data moving through the gateway. If alarm rule is triggered an email notification can be sent.
Gateway Security	You can configure up to 9 different users access to diagnostic and configuration screens.
Translation Table	Allows for data manipulation during protocol translation. Scaling and other data format changes can occur in the gateway.
Status and Counters	Protocol specific status, counters, and error messages are accessible within the gateway's diagnostics page. They can also be delivered to a connected device.
Diagnostic Logging Page	Allows users to see and log start up sequences, protocol specific messages & error messages.

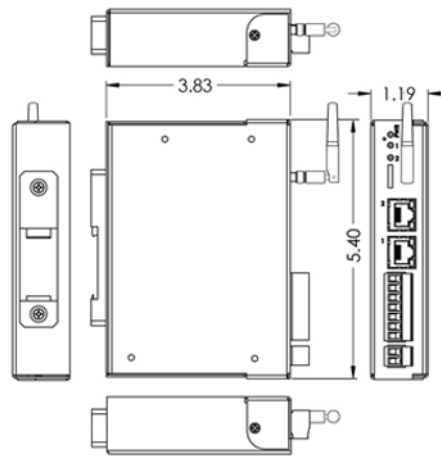

NOT EXACTLY WHAT YOU WERE LOOKING FOR?
 Real Time Automation offers a full line of gateway products. Give us a call at 1-800-249-1612. Or, check out a listing at www.rtautomation.com/products. We also offer customizations for unique applications.

CATALOG #	DESCRIPTION
460ETCMM-N2EW	Connects up to five Allen-Bradley PLCs with as many as 32 Modbus RTU Servers over Wireless



ALWAYS IN STOCK



READY TO SHIP

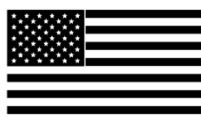

MADE IN THE USA



EXPERT SUPPORT



5-YEAR WARRANTY



EMPLOYEE OWNED