

## Modbus TCP/IP to Allen-Bradley PLC

### FEATURES

- Supports connection to five Allen-Bradley PLCs
- Up to 150 tag or file arrays of data can be mapped in each direction
- Fully configurable Modbus TCP/IP server
- Move up to 100 groups of 512 contiguous coils or 512 contiguous registers to or from your Modbus TCP/IP client
- Effortless Browser Based Configuration, no programming software is required
- Simple data translation allows you to manipulate data as it passes between protocols
- 5-Year Hardware Warranty

### Get Your Modbus TCP/IP Client Connected Directly to the Data Table of Your Allen-Bradley PLC

The 460ETCMS moves data between a Modbus TCP/IP client device and one to five Allen-Bradley PLCs. It's a simple tool to help you integrate legacy or low cost Modbus TCP/IP controllers into your CompactLogix architecture. Best of all, the product is made in the USA, always in stock, and comes with 5-year warranty.

### How Do I Use the 460ETCMS-NNA1 in My Application?

You allocate two blocks in your Allen-Bradley PLC. One area is write only tags or register blocks accepting data from your Modbus TCP/IP device. The other area is read only tags or register blocks to send data to your Modbus TCP/IP device. It's really that simple. Need to modify your data as it passes from one protocol to the other? No problem. Each data mapping you apply can be modified.

### Why Use Real Time Automation as a Gateway Supplier?

While there are certainly other companies offering protocol gateways, there is no one who provides the level of support and service that you receive from RTA.

When you call, a live person answers the phone. When you talk with sales, you will get honest answers and recommendations. When you get support, it is from an engineer who had a hand in the product's development, and support doesn't require a ticket or 24-hour wait.

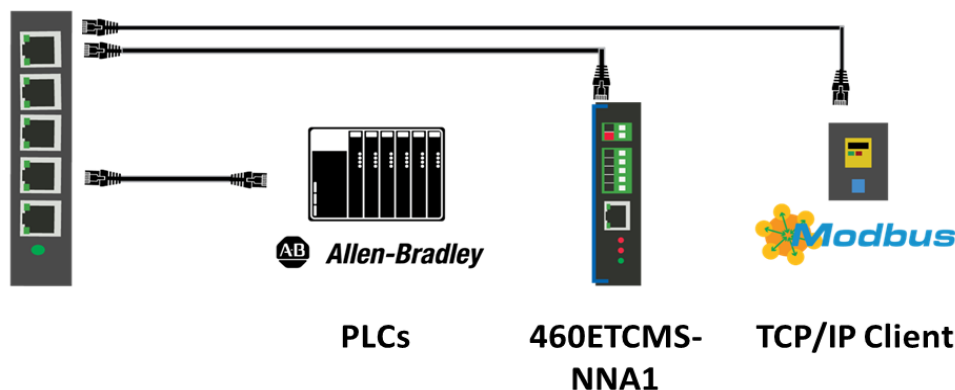

**A Solution, A Philosophy, the RTA Way.** We understand the long hours spent on a factory floor and the pressure to keep a line running and product flowing. That's how Real Time Automation came to be. You want easy-to-use solutions where the hardest part is to open the box. You need customer support second to none. If you get all that and a fun customer experience all the better. Thirty years later, our mission remains the same: **To move your data where you need it, when you need it, and how you need it.**

Ethernet Tag Client FEATURES	
PLC Support	ControlLogix, CompactLogix, FlexLogix, MicroLogix, SLCs and PLC5Es
Maximum Number of PLCs Supported	5
Maximum Number of Input/Output Tags or Files per PLC	150
Maximum Number of Bytes per PLC Tag	400
Array Support	Yes, for all data types except strings
Supported Data Types	Usint, Sint, Uint, Int, Udint, Dint, Real, String, Bit Array 16, Bit Array 32, Bool, and Long
Modbus TCP Server FEATURES	
Operation Mode	Modbus TCP/IP Server
Function Codes Supported	1,2,3,4,5,6, 15 & 16
Swapping	Byte and Word Swapping
Maximum Modbus TCP/IP Client Connections	10
Contiguous Data Areas	200 Total - 100 reads & 100 writes
Data Area Limits	512 Contiguous Coils or 512 Contiguous Registers
INCLUDED WITH GATEWAY	
3' power cable with flying leads	5-year hardware warranty
IPSetup software – automatically locates RTA gateway on the network	Unlimited firmware feature upgrades for life
CAT5 crossover cable for direct connection to PC during programming	Complete, unlimited access to our industry leading support staff
Manual	

ELECTRICAL / ENVIRONMENTAL	
DC Input Voltage	12-24 VDC
Maximum Baud Rate	115K baud
Operating Temperature	-40 C to 85 C
Certification	RoHS-Compliant, UL, CUL, CE Approvals
ENCLOSURE / HARDWARE	
Size	3.88" x 2.57" x 1.06"
Weight	5.5 oz
Enclosure Type	Anodized Aluminum
Mounting	Din rail or panel mount
LEDs	Power LED & 2 general purpose LEDs on side
GATEWAY FEATURES & FUNCTIONS	
Alarming	Set <, <=, >, >=, ==, !=, and change-of-state rules on any data moving through the gateway. If alarm rule is triggered an email notification can be sent.
Gateway Security	You can configure up to 9 different users access to diagnostic and configuration screens.
Translation Table	Allows for data manipulation during protocol translation. Scaling and other data format changes can occur in the gateway.
Status and Counters	Protocol specific status, counters, and error messages are accessible within the gateway's diagnostics page. They can also be delivered to a connected device.
Diagnostic Logging Page	Allows users to see and log start up sequences, protocol specific messages & error messages.

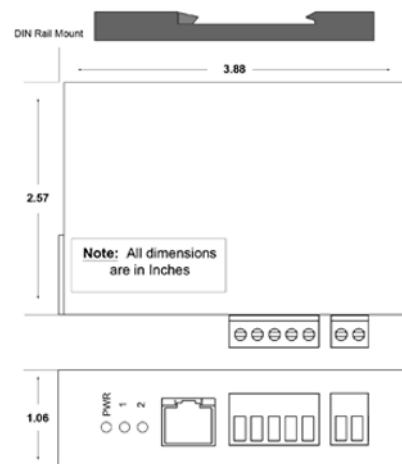

**NOT EXACTLY WHAT YOU WERE LOOKING FOR?**  
 Real Time Automation offers a full line of gateway products. Give us a call at 1-800-249-1612. Or, check out a listing at [www.rtautomation.com/products](http://www.rtautomation.com/products). We also offer customizations for unique applications.

CATALOG #	DESCRIPTION
460ETCMS-NNA1	Connects up to five Allen-Bradley PLCs with a Modbus TCP client



MADE IN THE  
**U.S.A.**



ALWAYS IN  
**STOCK**



READY TO  
**SHIP**



EXPERT  
**SUPPORT**

